

DUCATI SCRAMBLER - 2015-17

Paratelaio - Frame Protector

PTVA84

Lato Cambio / Shift Side

Lato Freno / Brake Side

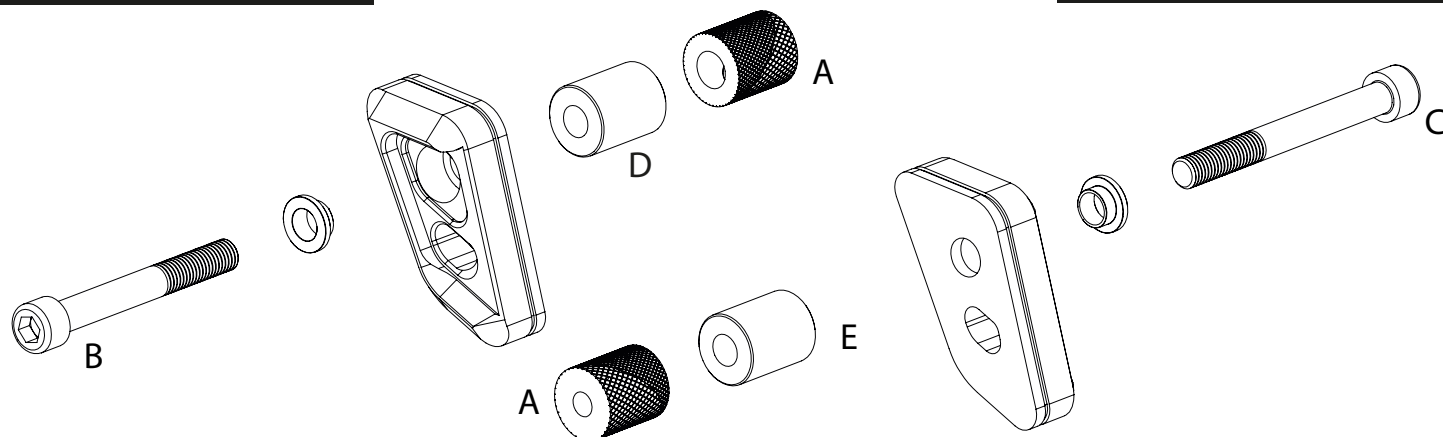

LETTER	DESCRIPTION	UNITS
A	<i>espansore M8 ø 23,5 M8 ø 23,5 expander</i>	2
B	M8 L 75	1
C	M8 L 100	1

LETTER	DESCRIPTION	UNITS
D	<i>distanziale L 45 mm 7.5 mm spacer</i>	1
E	<i>distanziale L 65mm 45 mm spacer</i>	1

DUCATI SCRAMBLER - 2015-17

Paratelaio - Frame Protector

PTVA84

Lato Cambio / Shift Side

Lato Freno / Brake Side

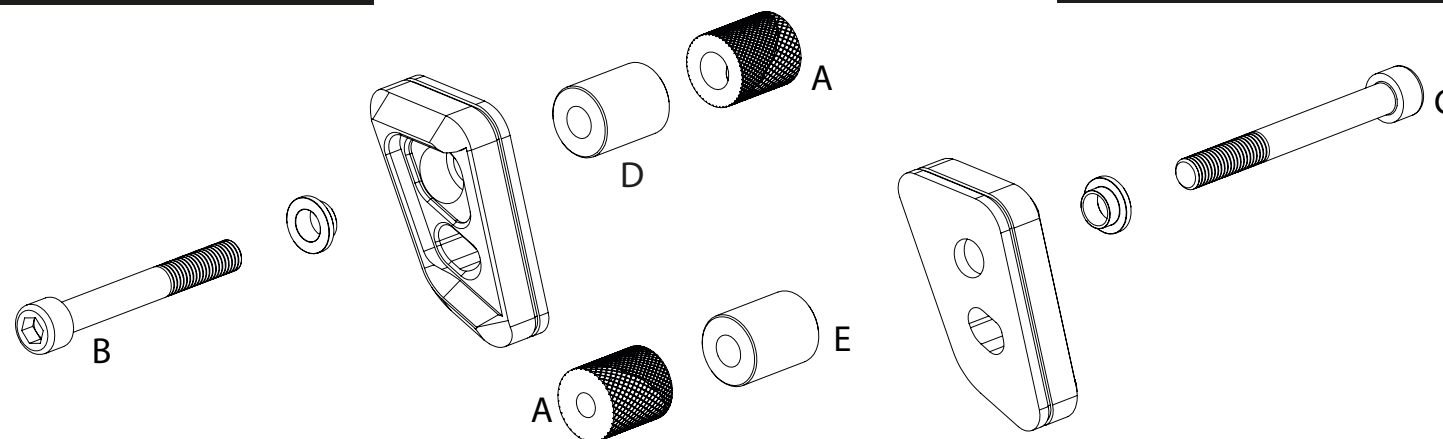

LETTER	DESCRIPTION	UNITS
A	<i>espansore M8 ø 23,5 M8 ø 23,5 expander</i>	2
B	M8 L 75	1
C	M8 L 100	1

LETTER	DESCRIPTION	UNITS
D	<i>distanziale L 45 mm 7.5 mm spacer</i>	1
E	<i>distanziale L 65mm 45 mm spacer</i>	1